

NARRATIVE LAMINATE BASE INSTALLATION INSTRUCTIONS

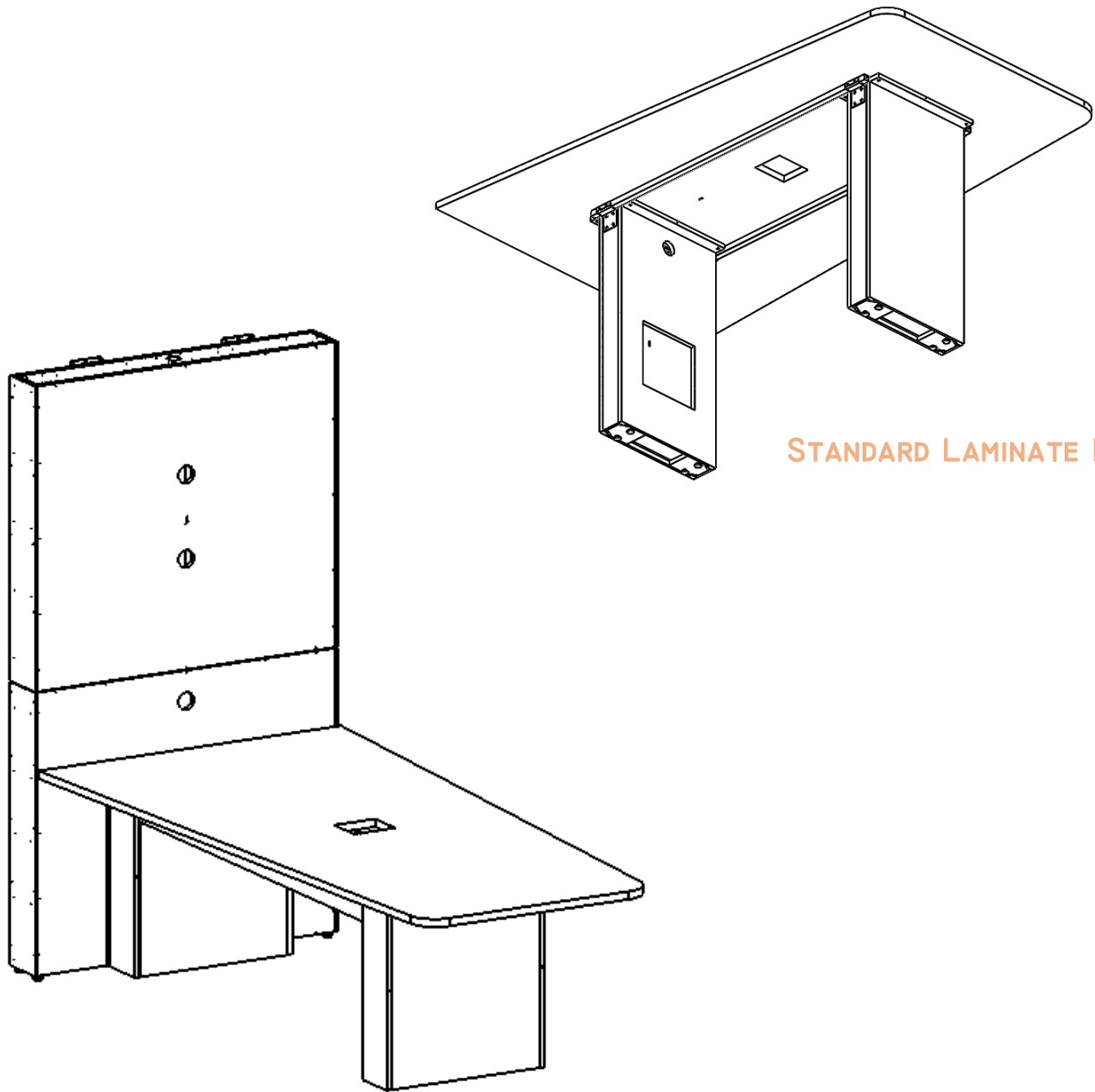

STANDARD LAMINATE BASE

HEIGHT ADJUSTABLE LAMINATE BASE

INSTALLATION INSTRUCTIONS

For STANDARD Laminate Base

Materials Needed:

1. Screws, #8 x 1-1/2" L FLH, 8 pieces
2. Screws, #10 x 1" L PNH, 12 pieces (extras included)
3. Screws, #8 x 1/2" L HXHD, 8 pieces

POSITION LAMINATE BASE

NOTE: Base to be positioned 20 inches from edge of table to center of laminate base.

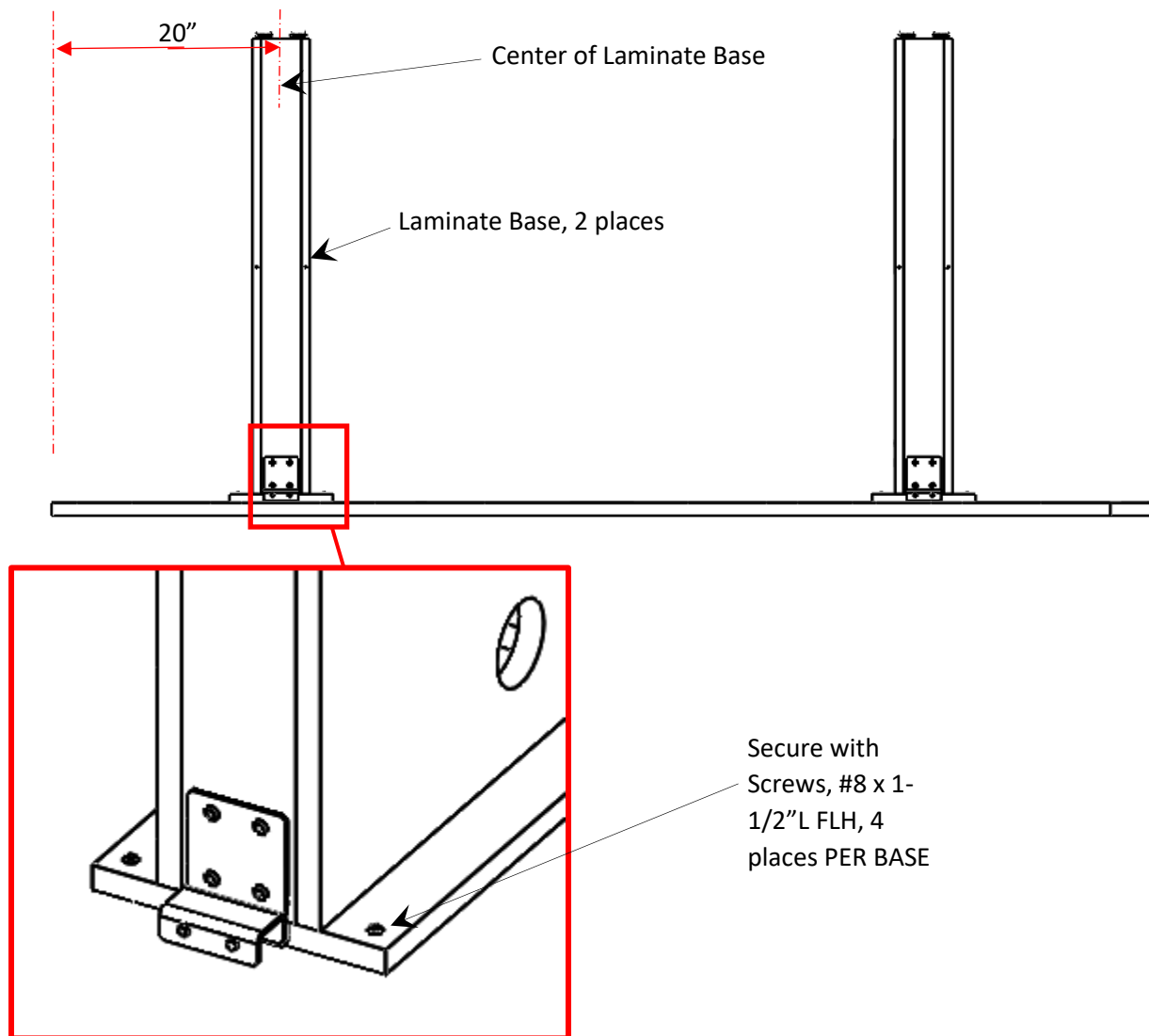

INSTALLATION INSTRUCTIONS

2 SLIDE SPANNING RODS AS SHOWN. SECURE RODS ONTO TABLE AS SHOWN;

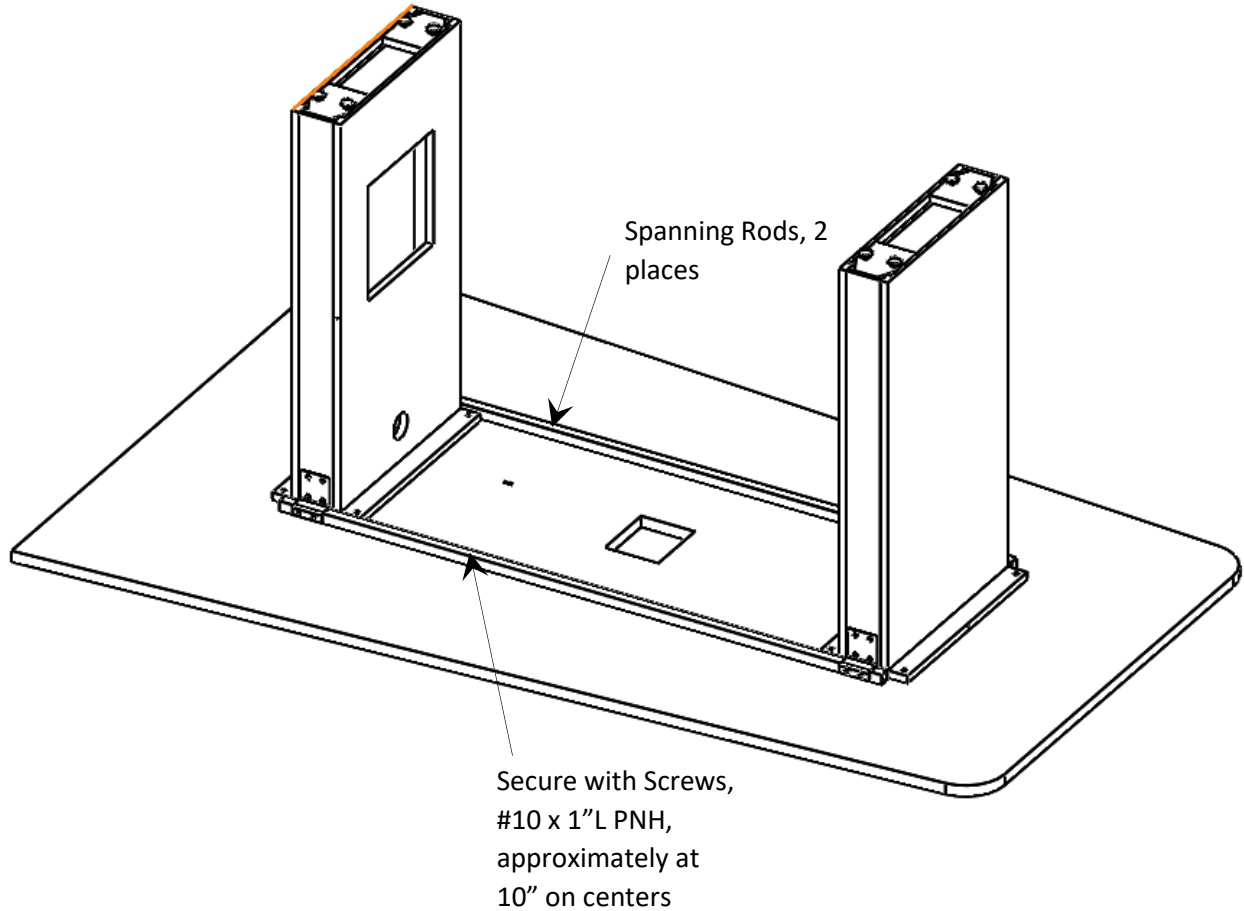

3 SECURE SPANNING RODS TO U-BRACKET MOUNTED ON THE LAMINATE BASE AS SHOWN.;

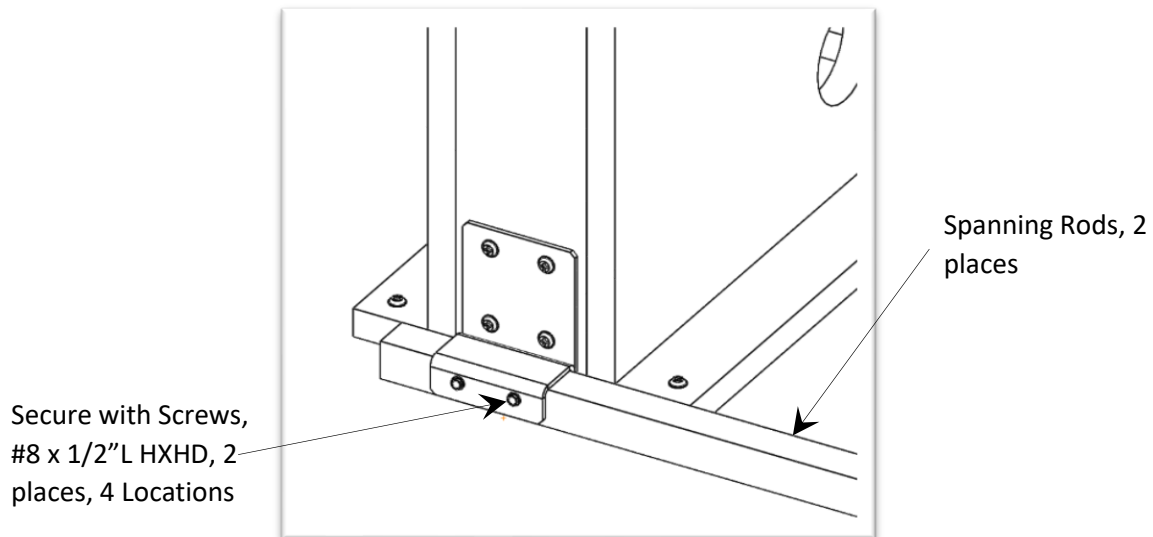

INSTALLATION INSTRUCTIONS

For HEIGHT ADJUSTABLE Laminate Base

Materials Needed:

1. Screws, #8 x 1/2" L PNH, 1 Lot
2. Screws, #8 x 3" L FLH, 6 places

ASSEMBLE STRETCHER TO LAMINATE BASE

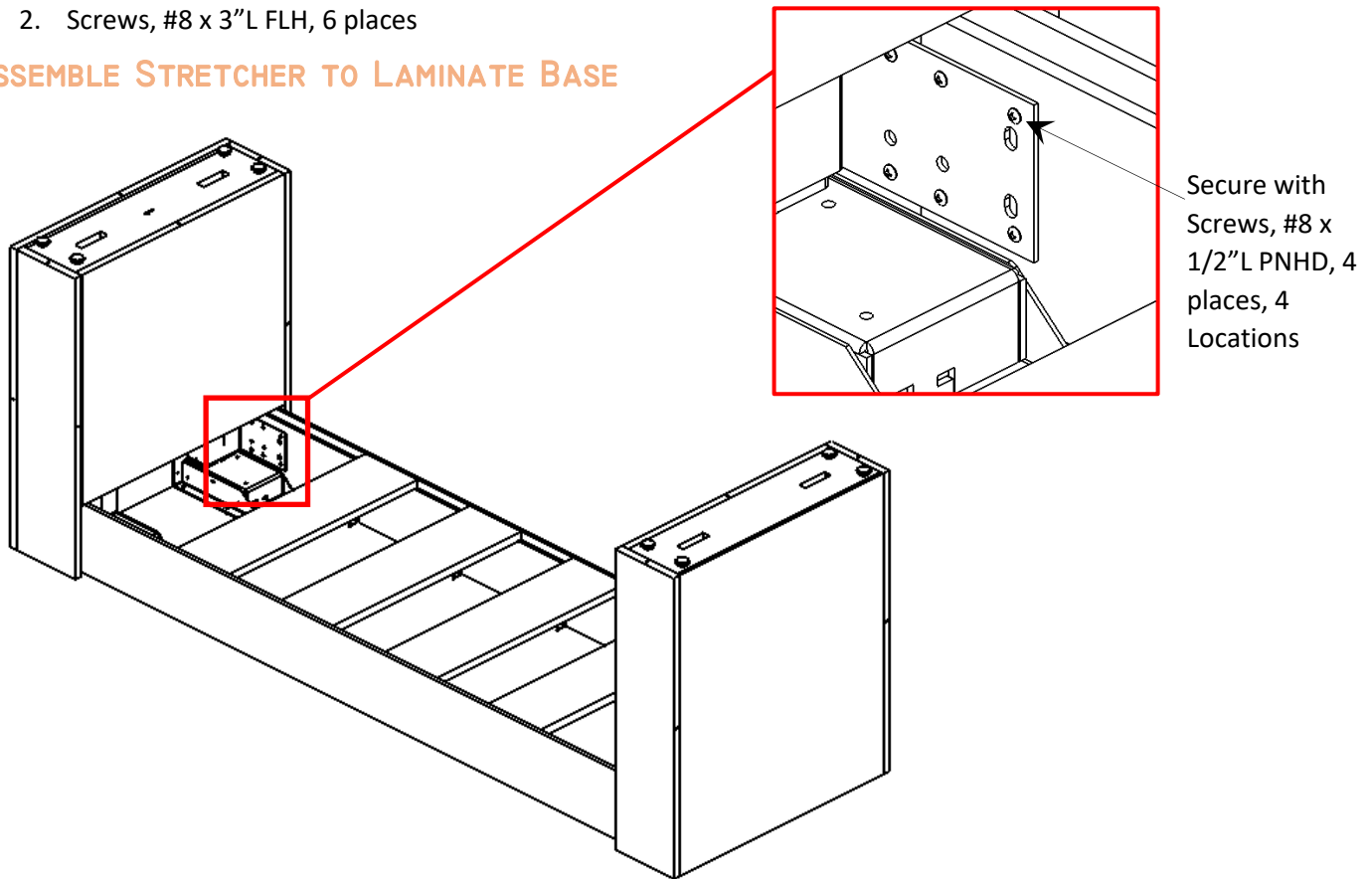

2 POSITION LAMINATE BASE ASSEMBLY ONTO UNDERSIDE OF TABLE AS SHOWN.

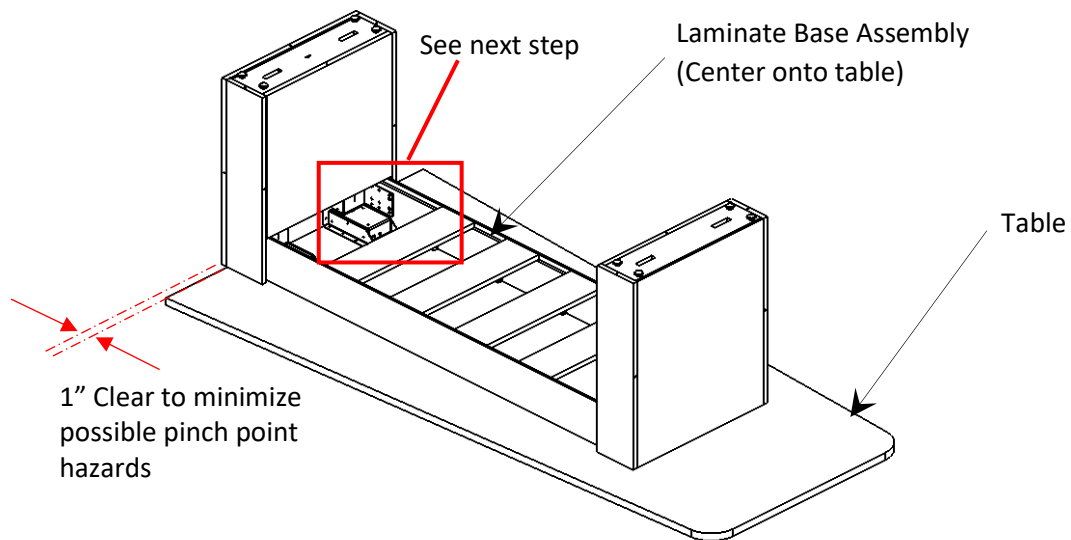

INSTALLATION INSTRUCTIONS

3 SECURE LAMINATE BASE ASSEMBLY ONTO UNDERSIDE OF TABLE AS SHOWN

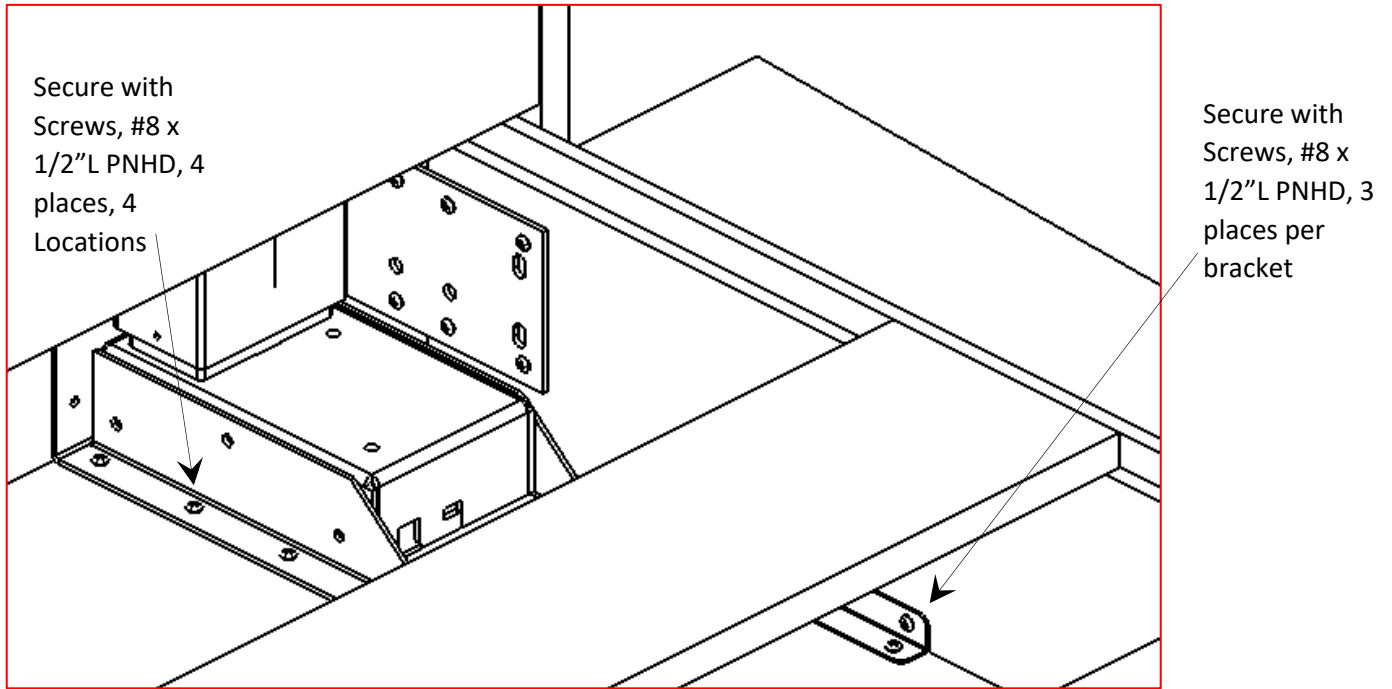

INSTALLATION INSTRUCTIONS

- 4** SECURE LAMINATE BASE ASSEMBLY WITH TOP ONTO MONITOR WALL USING #8 X 3" L SCREWS.

