

NARRATIVE WALL AND TABLE INSTALLATION INSTRUCTIONS

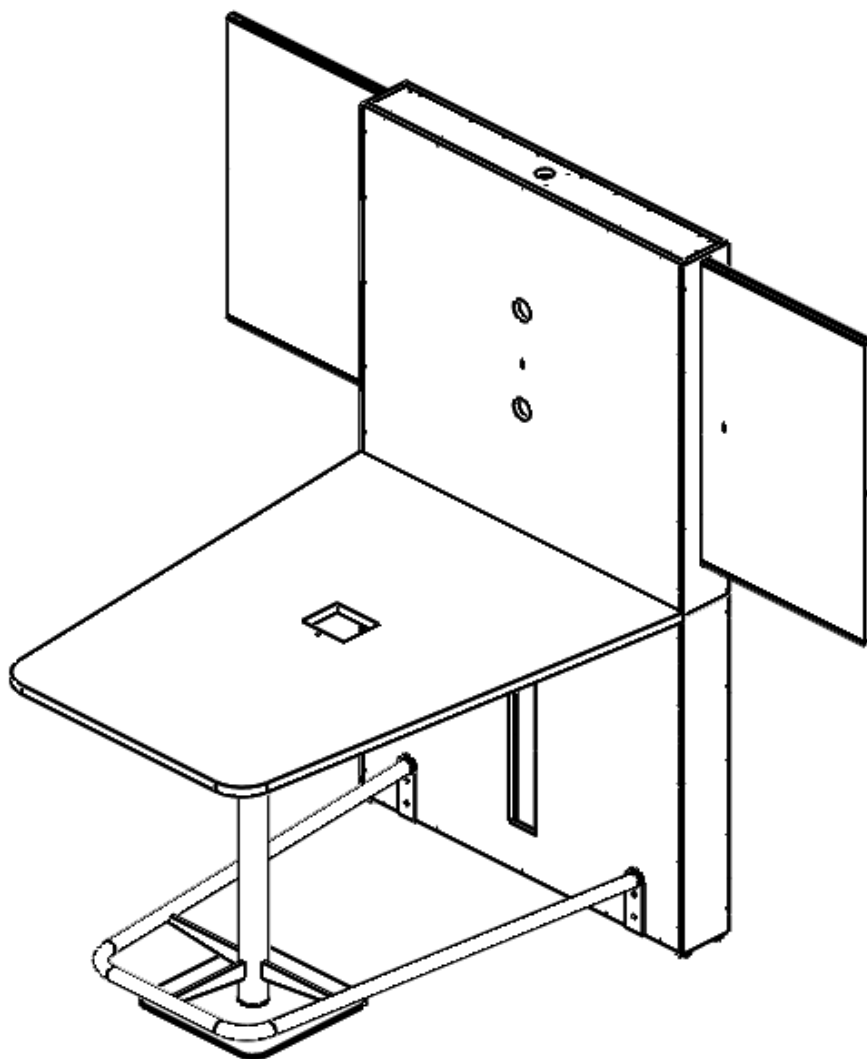

INSTALLATION INSTRUCTIONS

Materials Needed:

For Monitor Wall Assembly

1. Bolt, $\frac{1}{4}$ "-20 x 3-1/2"L, HEXHD Full Thread, 8 pieces
2. Nut, $\frac{1}{4}$ "-20, 8 pieces
3. Lock Washer, $\frac{1}{4}$ ", 8 pieces
4. Washer, $\frac{1}{4}$ ", 8 pieces
5. Grommet, 2.5" Black, 3 pieces
6. Grommet, 1" Black, 4 pieces

For Worksurface Assembly

7. Screw, No. 14 x 1-1/2"L, Pan Head, 18 pieces [Not for securing worksurface]
8. Screw, No. 10 x 1"L, Pan Head, 30 pieces [For securing bracket onto worksurface]

For Securing Monitor Wall Assembly onto Wall Structure

9. Screw, No. 8 x 1-3/4"L, Flat Head, 12 pieces
10. Bracket, $\frac{3}{4}$ " x 5"L, Black, 2 pieces

PRE-ASSEMBLE L-BRACKET ONTO BOTTOM WALL;

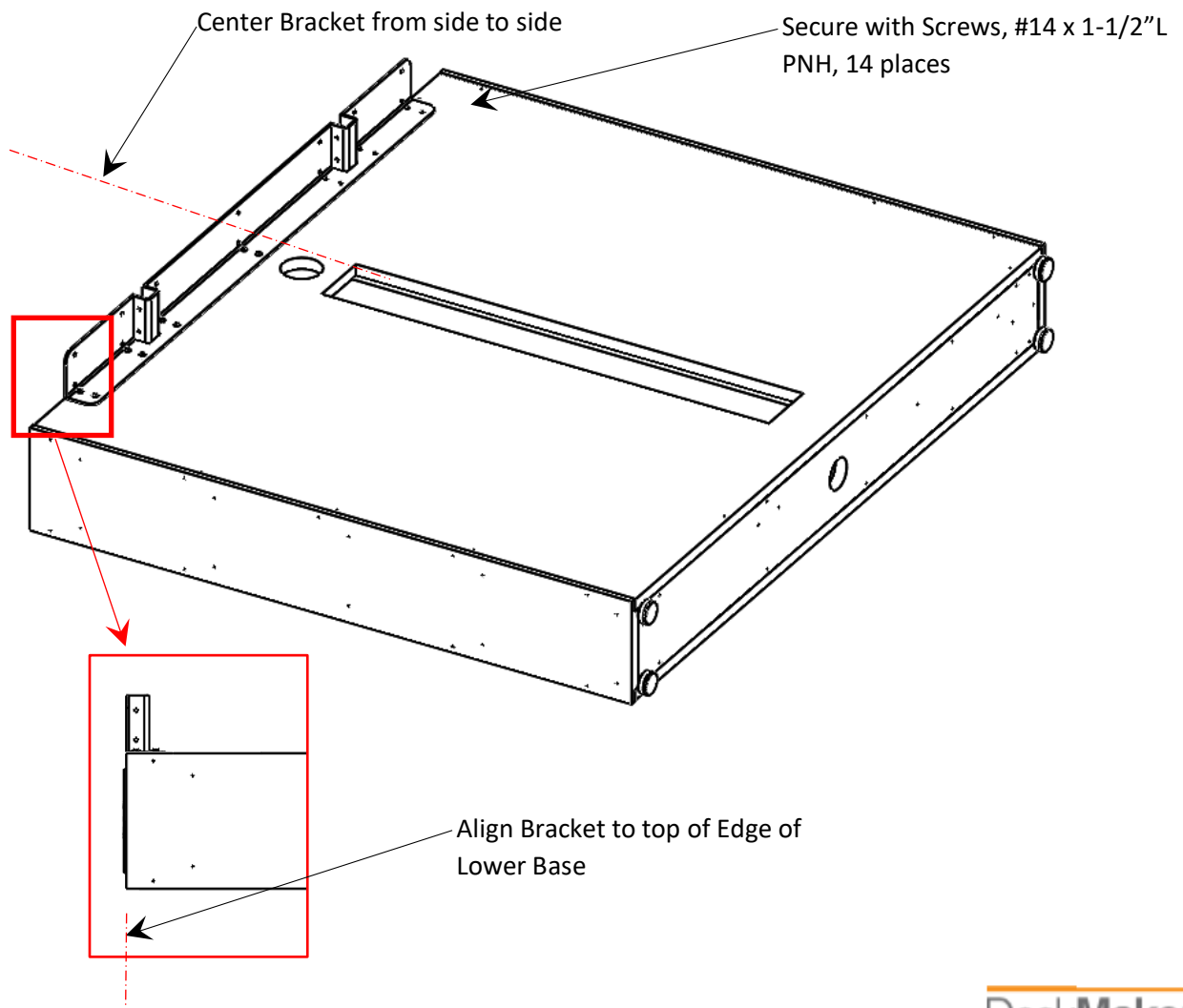

INSTALLATION INSTRUCTIONS

2 POSITION BOTTOM WALL UPRIGHT AS SHOWN BELOW AND LEVEL HORIZONTALLY AND VERTICALLY;

NOTE: Due to the substantial weight of the assembled unit, it is best to assemble at the location where it will be used.

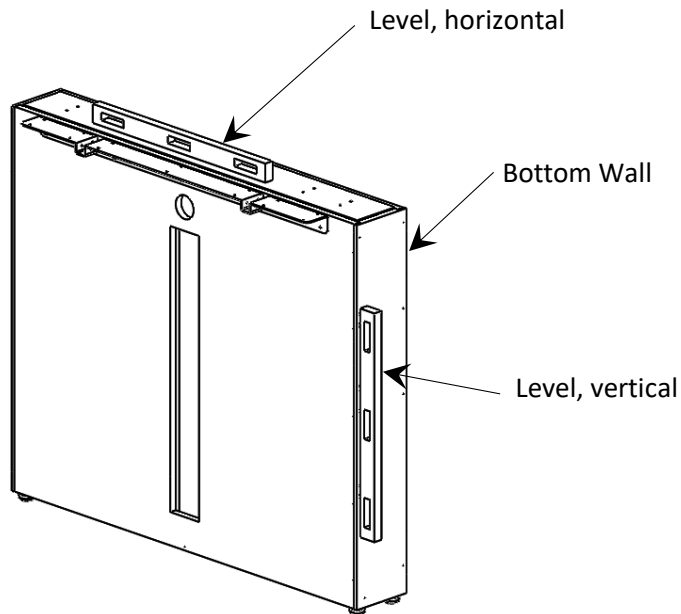

3 POSITION METAL BASE AS SHOWN BELOW AND LEVEL HORIZONTALLY AND VERTICALLY;

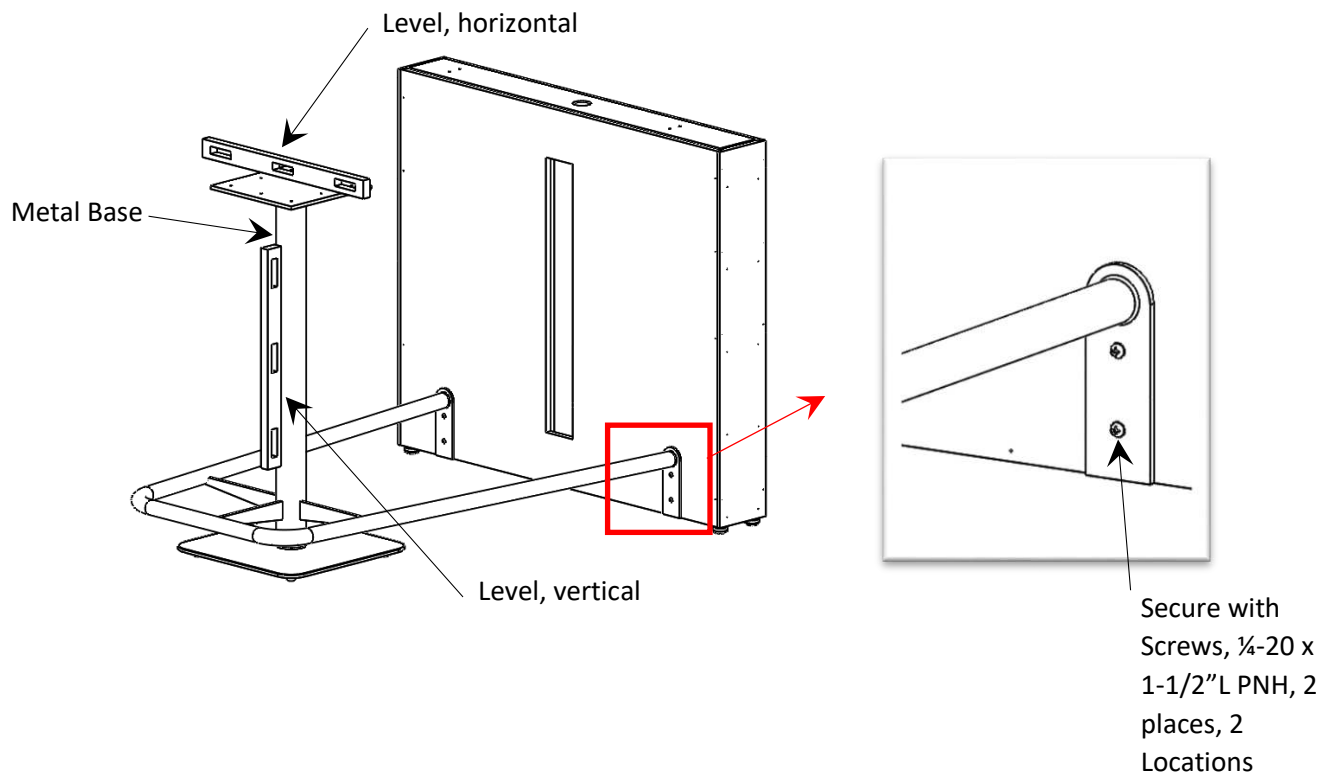

INSTALLATION INSTRUCTIONS

4 POSITION TOP WALL ON TOP OF BOTTOM WALL AND SECURE WITH BOLTS (8 PLACES)

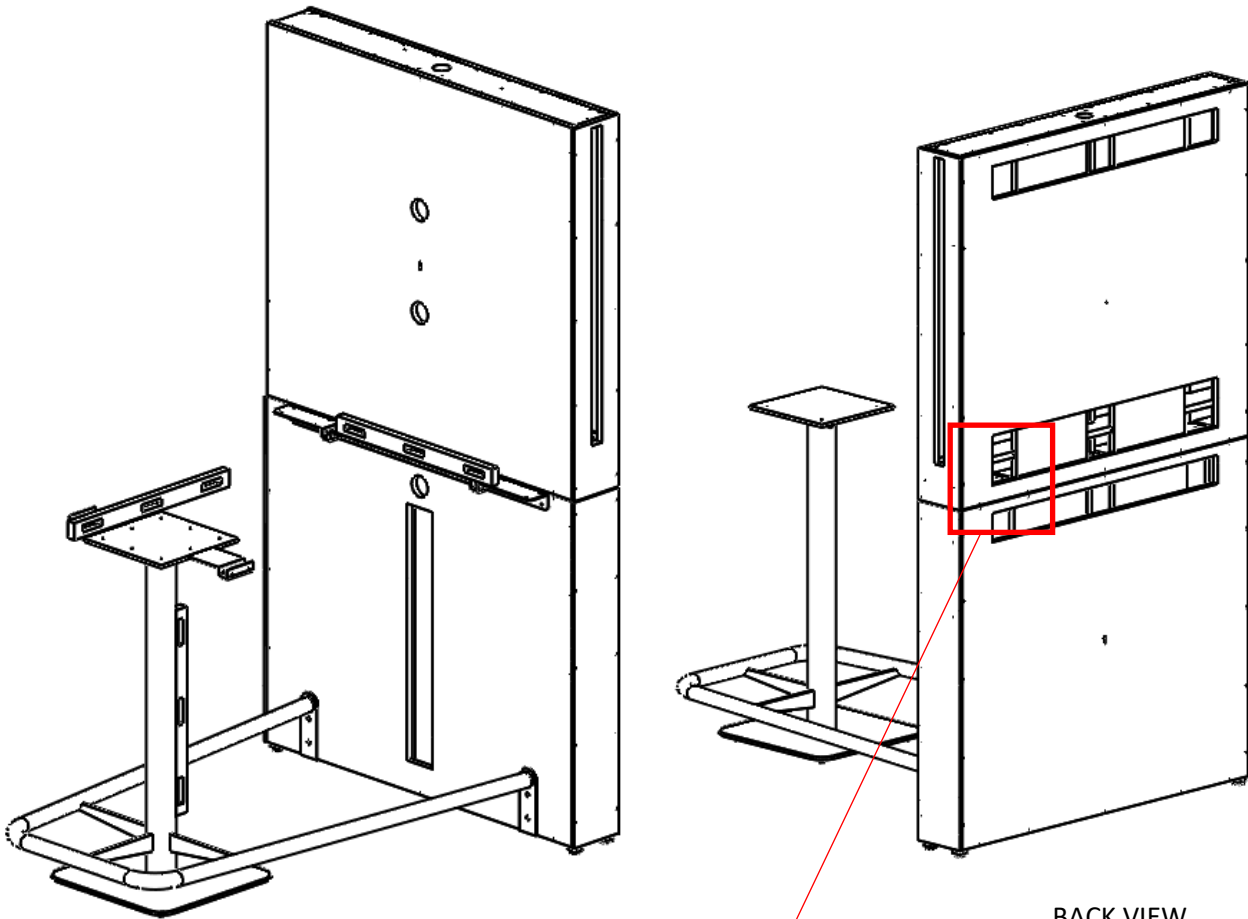

Secure with
Screws, 1/4-20 x
3-1/2" L HEXHD,
4 places, 2
Locations

INSTALLATION INSTRUCTIONS

5 POSITION TABLE AS SHOWN BELOW AND CHECK FOR LEVEL. THEN SECURE TABLE ONTO WALL WITH SCREWS.

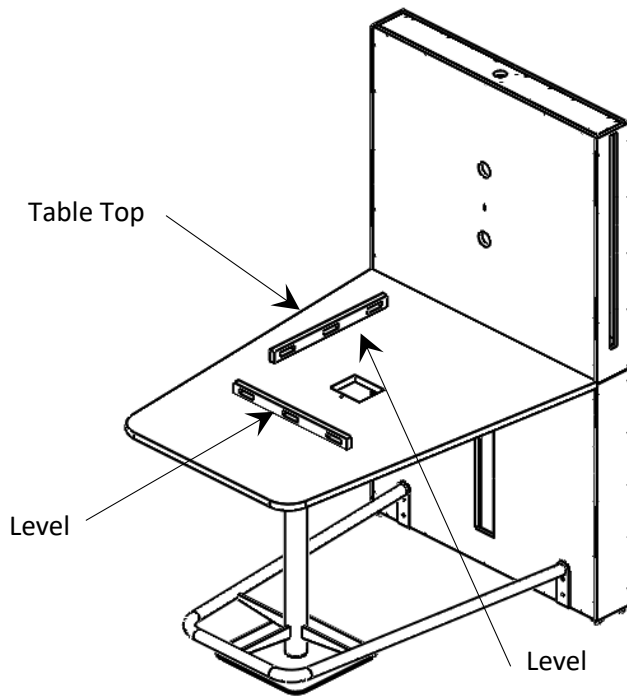

INSTALLATION INSTRUCTIONS

6 SECURE TABLE TOP ONTO THE METAL BASE. INSERT SPANNING RODS AND SECURE IN PLACE.

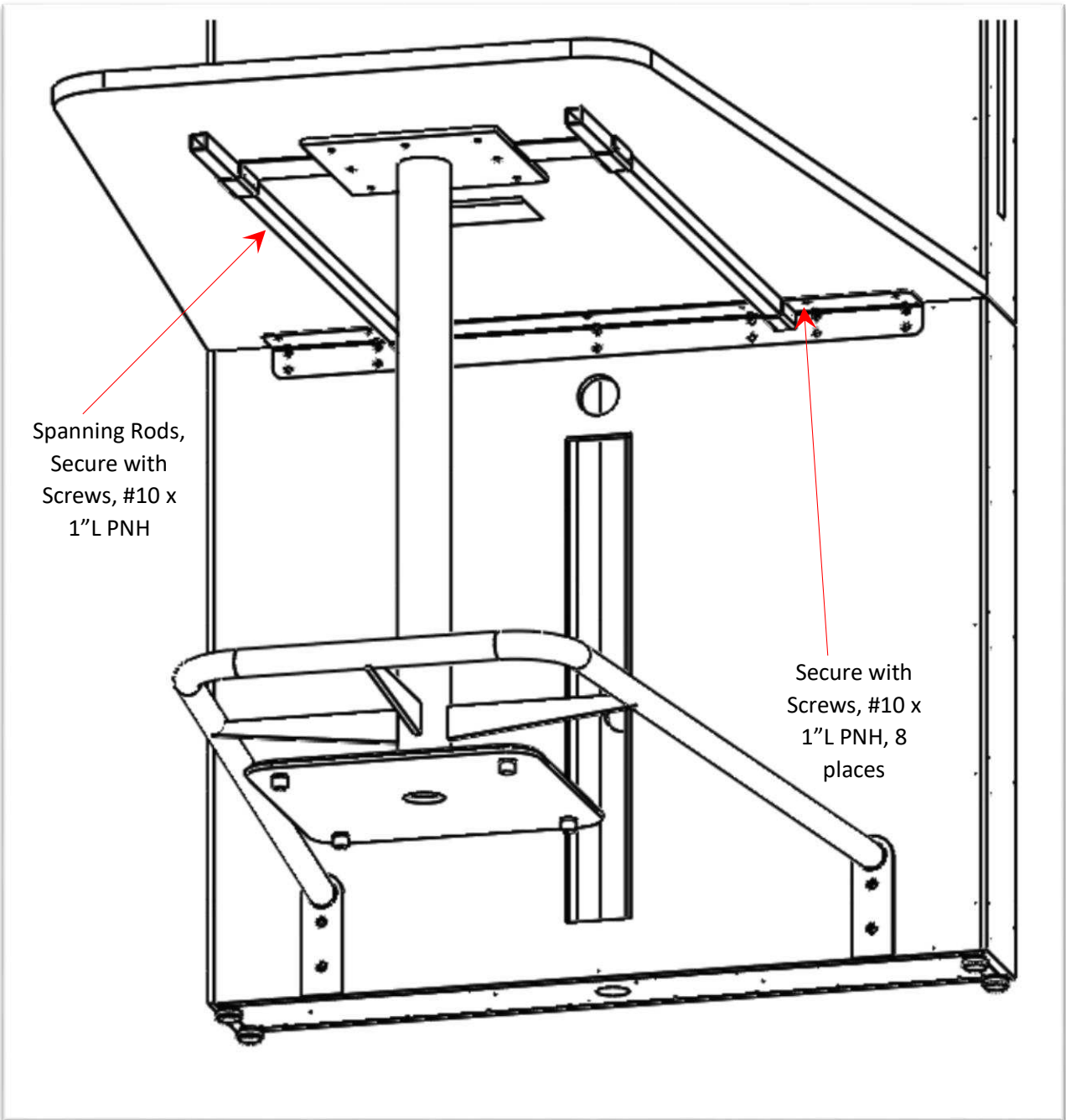

INSTALLATION INSTRUCTIONS

7 USE BRACKETS AND SECURE TO WALL.

