

# STACK-ON ASSEMBLY

*Note: Stack-On Counters may be assembled onto different Desk Configuration.*

1. Assemble L-Shape Stack-On using Tite-Joint and screws (provided)



2. Position Side Stack-On Counter onto the table as shown in design drawings. Ensure no gap between long and short side stack-on.

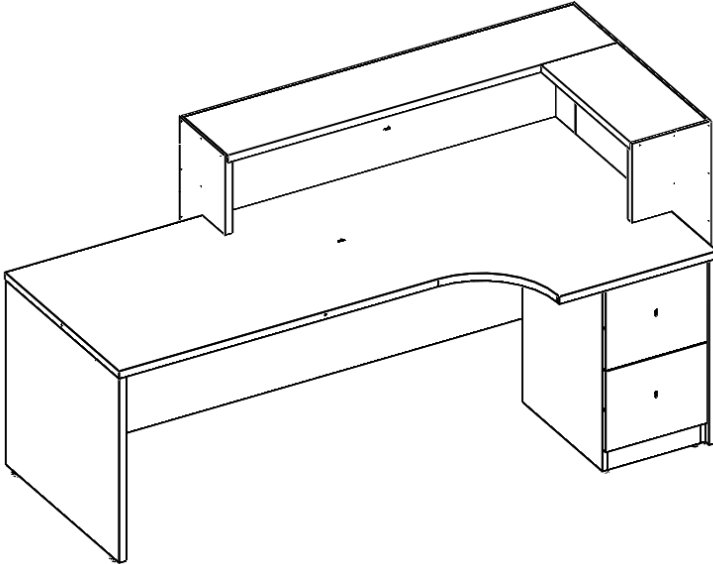

3. Mark End Location of stack-On Counter on the modesty panel.

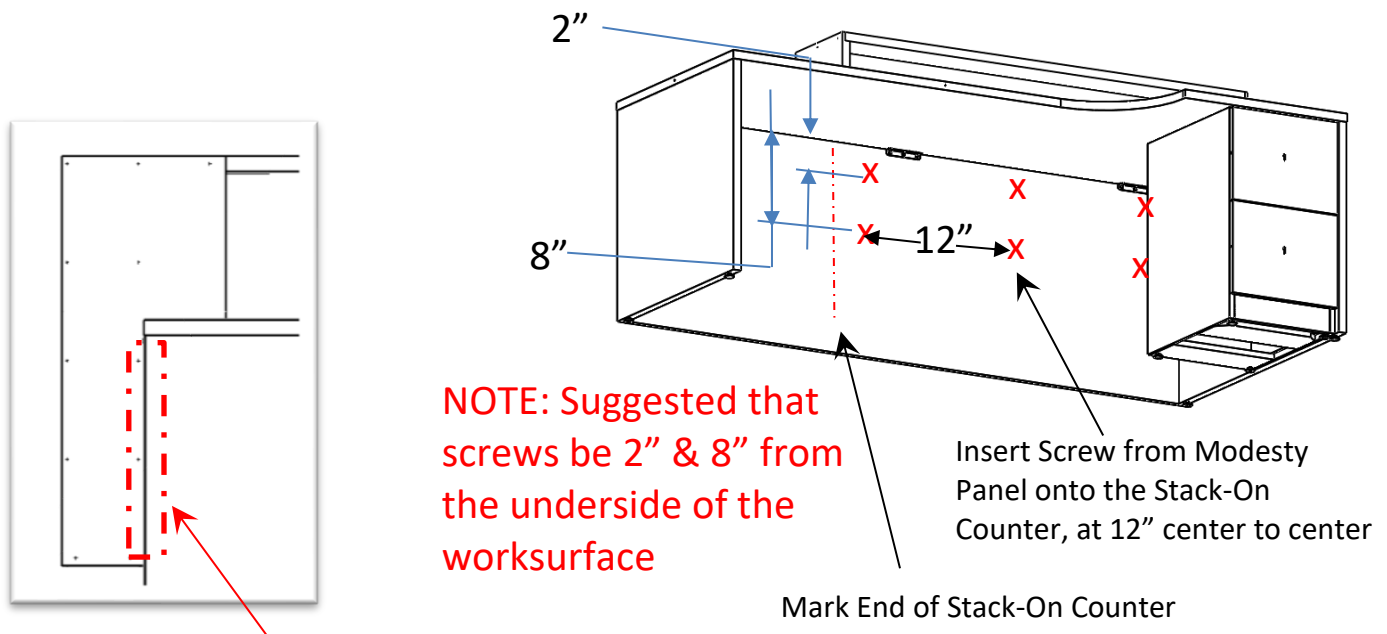

**NOTE: there's a clearance space of approximately 1/16" created by edgeband between the modesty panel and the stack-on. This is normal.**

4. Repeat Step 3 and secure Short Side Stack-On onto the side panel. For areas in way of the Pedestal, remove drawers and screw from inside the pedestal onto the stack-on counter (Note: This will require a longer screw to reach the stack-on).